

# **G GLENSOUND ELECTRONICS LTD**

---

Date 22/06/00

File AP71-14

Issue 1

---

## **GSGC5G ISDN MIXERS PRODUCT DETAILS**

### **CONTENTS**

Approvals	Page 1
General Information	Page 2
Installation information	Page 3
Operating Instructions	Page 4
Software Configurations	Page 6
Hardware Configurations	Page 10
MPEG Notes	Page 11

A2-14030	Panel View
A4-14194	Block Diagram
A3-14196	GSP45 Circuit Diagram
A2-14198	GSP46 Front PCB Circuit Diagram
A3-12586	GSH86 Circuit Diagram
A4-12580	Power Supply Circuit
AP13-09	Specifications (2 Pages )

# APPROVALS

---

C E

This product conforms to the requirements of EMC DIRECTIVE 89/336/EEC

Emissions Standards EN 50081-1

Immunity Standards EN 50082-1

---

## **BABT APPROVAL REQUIREMENTS FOR THE UNITED KINGDOM**

This device incorporates a Dataflex Design ISDN Basic Rate Module which has been approved by the British Approvals Board for Telecommunication (BABT) for connection to the Integrated Services Digital Network (ISDN). The following approval number has been given to this product:

**NS/3010/5/P/603977**

---

## **NET 3 APPROVAL**

This product is fully approved for use as a digital terminal adapter on any PSTN using a basic rate access interface compatible with CCITT I.420 (NET3).

---

## **BRIDGING CTR APPROVAL**

The terminal adaptor used in this unit is the Dataflex IM90C module. This module has bridging CTR approval so that the GSGC4 & 5 units are approved for use in any country in the EEC

---

## **SWISS BAKOM APPROVAL**

This unit has also got approval for use in Switzerland. The approval number is :-

**BAKOM 95.0545.I.N**

## **GENERAL INFORMATION**

The GSGC4 and GSGC5 units are very similar. The GSGC4 being a cut down version of the GSGC5 primarily for use by a reporter, while the GSGC5 has more channels and would normally be used where more than 1 person is contributing . Both units are designed to make it very easy to send a programme to an ISDN line.

These units can be supplied with various Codecs. The types available are :-

G722

APTX

DUAL (APTX/G722)

ISO/MPEG LAYER 2

The type fitted is clearly indicated on the rear panel of the equipment.

Full operating instructions are given on page 4 while later pages in this booklet explain how to configure the unit to suit your own requirements.

This booklet does not include full circuit diagrams of all parts of the equipment but does show details of most of the audio chain along with the power supply arrangements. The Codec, Terminal Adapter and Microprocessor circuits are not shown because they could not reasonably be maintained by the customer. If any faults develop in these parts please send the whole equipment back to us for repair.

## **INSTALLATION INFORMATION**

## **ISDN INSTALLATION**

To install this equipment refer to drawing A2-12812. It is only necessary to:-

- 1) Plug in the ISDN cable (RJ45) from the mixer to the BT ISDN point.
- 2) Plug in the Mains PSU (if required) from the rear of the mixer to a standard 13amp mains socket.
- 3) Plug in the 1 or 2 Headsets into the connectors on the front of the mixer.

## **X21 INSTALLATION**

Please ignore this section if you are only using the equipment on ISDN.

There is a rear panel X21 interface to permit the connection of an external terminal adapter or any other compatible data circuit such as a satellite. The X21 connector is a 15pin D fixed socket with the following standard pinout:-

Pin 1 =	Shield
Pin 2 =	Transmit data (leg A)
Pin 3 =	Control (leg A)
Pin 4 =	Receive data (leg A)
Pin 5 =	Indicate (leg A)
Pin 6 =	Element timing (leg A)
Pin 7 =	Byte timing A Input (Optional Negative frame pulse)
Pin 8 =	Signal Ground
Pin 9 =	Transmit data B Output (Data from Codec)
Pin 10 =	Control B Output (Pulse high when 'Hang-up' pressed)
Pin 11 =	Receive data B Input (Data to Codec)
Pin 12 =	Indicate B Input (Low enables X21)
Pin 13 =	Element timing B Input (Data latched on low to high transition)
Pin 14 =	Byte timing B Input (Optional Positive frame pulse)
Pin 15 =	No Connection

This interface will only operate at 64Kbits/sec. It is not suitable for use at 56Kbits/sec. The equipment will operate if both the ISDN and the X21 ports are connected. Under these circumstances the first incoming call will be accepted by the equipment. If a subsequent call comes in on the other circuit while the box is on line, the ISDN led is made to flash.

# OPERATING INSTRUCTIONS

## POWER

This equipment is usually powered from its own internal D Cells. These must be alkaline cells, such as 'DURACELL DB2'

This equipment can also be powered from an external DC supply. There is a 3 position switch on the rear panel marked 'EXT-OFF-BATT' . If operated in the external position while the external supply is plugged in and present, the equipment will operate from the external supply until it fails, when the batteries will take over automatically without losing the line. To turn on the box select Battery or External. After a few seconds the power light will come on. If it flashes, the batteries are low and should be replaced. The unit will work for about a further half hour after the power light starts to flash.

To change the batteries use a coin to open the battery container on the left hand side of the box. Replace all 3 batteries ensuring that the positive ends ( the end with the small cap) are pointing out of the box.

## CONNECTION TO ISDN2 LINE

Supplied with the equipment is a lead with an identical plug on both ends. One end must be plugged into the ISDN connector on the rear panel of the equipment and the other end must be plugged into an ISDN2 circuit.

## TO ANSWER AN INCOMING CALL

This equipment can be set to automatically answer incoming calls or to wait for you to press the answer button. ( See Software Configurations)

If it is configured to be manually answered an incoming call will cause the 'ISDN LINE' light to flash and ringing to be heard in the headphones and possibly in the front panel sounder.

To answer momentarily press the answer button. Instantly the 'ISDN LINE' light should go steady and after a few seconds the 'CODEC OK' lamp should light.

It should now be possible to talk to and hear the studio.

## DIALING

To dial the studio first press and hold the 'HOLD TO DIAL' switch. Then dial the number required. Then release the 'HOLD TO DIAL' switch. It is the action of releasing the 'HOLD TO DIAL' switch that tells the box that your number is complete and can be sent to line.

When the switch is released 'ringing tone' will be heard in the headphones. If the connection is successful the ISDN LINE Lamp will light. If not successful the 'ringing tone' will change to 'number unobtainable' or 'engaged' tones.

After the connection has been made, the 'CODEC OK' light should turn on. This will only happen if the called studio has a compatible codec.

## DIALING A SUB-ADDRESS

Proceed as for dialing. Before releasing the 'HOLD TO DIAL' switch, press '#' followed by the required sub-address. This equipment can only use '\*', '#' and numeric characters for a sub-address.

## **LAST NUMBER REDIAL**

A momentary press of the "REDIAL" button will redial the last number dialed. This button is inoperative if the ISDN light is on. That is if a call is already in progress. If the unit is switched off the last number dialed will be forgotten.

## **MEMORY REDIAL**

It is possible to save up to 12 frequently used numbers in non volatile memory. The Software Configuration section of this booklet explains how to save these numbers.

To dial one of these previously saved numbers, press and hold "REDIAL" . Then momentary press the "Keypad number" of the stored location. Then release the "REDIAL" button.

## **SIGNALING THE STUDIO USING DTMF TONES**

Once a successful call has been established with the studio it is possible to signal them using DTMF tones. This is done by holding the 'HOLD TO DIAL' button and pressing any number on the dial. The corresponding DTMF tone will be sent to the studio all the time both buttons are held.

Similarly the studio can signal the unit by sending any DTMF tone. This tone will be heard in the headphones and will cause the front panel sounder to sound if it has been enabled. See the software configuration section of this booklet.

## **SETTING UP THE MIXER**

The GSGC4 has only 2 input channels, one mic and one tape, while the GSGC5 has 2 extra mic channels. Each channel has an associated on off push button and a rotary level control associated with it. The rotary controls are used to balance the sources. A small column PPM is provided to help with the balance. A compressor / limiter follows the PPM so that the correct level is always sent to the studio.

## **THE HEADPHONES**

Normally the mixer output can only be heard in one ear and cue programme in the other. (See Hardware Configurations) Individual volume controls are provided for each of these signals.

## **USE WITH ANALOGUE LINES**

In the absence of an ISDN line the cue output becomes a cue input. This is transformer coupled and can be connected directly to an analogue control line and the studio can be heard in the headphones using the headphone volume control. Also the mixer output is transformer coupled and can be connected to a music line.

The DTMF generators and detectors are still operative in this mode so it is possible to use them to signal a suitably equipped studio.

# SOFTWARE CONFIGURATIONS

Several functions in this equipment can be set to meet your exact needs. These setups are held in non volatile RAM and will be remembered until changed. These functions are all set by turning the box off by the 'EXT-OFF-BATT' switch on the rear panel and then turning it back on while holding a particular combination of buttons. To confirm that you are in the programming mode the "POWER" LED lights immediately. (It usually takes several seconds)

## 1) TO RESTORE THE FACTORY DEFAULT SETTINGS :-

Switch on while holding "HANG-UP" & "0".  
"POWER" LED lights immediately to confirm set-up operation.  
Release "HANG-UP" & "0".  
The "POWER" led turns off and then on.  
Default settings are now installed and normal operation continues.

## 2) SET THE POWER ON MIX :-

**Factory default has all channels off.**

*It is possible to arrange which channels are switched on when the equipment is powered up.*

Switch on while holding "HANG-UP" & "1".  
"POWER" LED lights immediately to confirm set-up operation.  
Release "HANG-UP" & "1".  
Select the required mix using the channel on/off switches.  
Turn the box off.

## 3) CHANNELS TO BE FORCED ON WHEN A CONNECTION IS MADE :-

**Factory Default has Mic A & Mic B forced on.**

*When a connection is made, regardless of if the box is manually answered, auto answered or originates a successful call, it is possible to ensure that any channels can be forced on despite their current state.*

Switch on while holding "HANG-UP" & "2".  
"POWER" LED lights immediately to confirm set-up operation.  
Release "HANG-UP" & "2".  
Select the channels to be forced on. Their LEDs will be on.  
Turn the box off.

#### **4) CHANNELS TO BE FORCED OFF WHEN A CONNECTION IS MADE :-**

**Factory default forces no channels off.**

*When a connection is made, regardless of if the box is manually answered, auto answered or originates a successful call, it is possible to ensure that any channels can be forced off despite their current state.*

Switch on while holding "HANG-UP" & "3"

"POWER" LED lights immediately to confirm set-up operation.

Release "HANG-UP" & "3"

Select the channels to be forced off. Their LEDs will turn off.

Turn the box off.

#### **5) SET THE ANSWER MODE :-**

**Factory default is manual answer.**

*It is possible to make the box automatically answer an incoming call or to wait until the "ANSWER" button is pressed.*

Switch on while holding "HANG-UP" & "4".

"POWER" LED lights immediately to confirm set-up operation.

Release "HANG-UP" & "4".

If the "ISDN LINE" LED is off the box is set for manual answer.

If the "ISDN LINE" LED is on the box is set for automatic answer.

Press "0" for manual answer.

Press "1" to automatically answer on the first ring.

Press "2" to automatically answer on the second ring.

Etc. for any number up to 9.

Turn the box off.

#### **6) SET ISDN RINGER MODE :-**

**Factory Default is sounder on.**

*An incoming call always flashes the "ISDN LINE" LED and produces ringing tone in the headphones. It is also possible to make it ring the front panel sounder.*

Switch on while holding "HANG-UP" & "5".

"POWER" LED lights immediately to confirm set-up operation.

Release "HANG-UP" & "5".

Press "0" for sounder off or "1" for sounder on.

Turn the box off.



## **7) SET DTMF RINGER MODE :-**

**Factory Default is sounder on.**

*When a call has been established an incoming DTMF tone can be made to operate the front panel sounder.*

Switch on while holding "HANG-UP" & "6".

"POWER" LED lights immediately to confirm set-up operation.

Release "HANG-UP" & "6".

Press "0" for sounder off or "1" for sounder on.

Turn the box off.

## **8) SELECT INCOMING ISDN B CHANNEL :-**

**Factory Default is either channel.**

*An ISDN2 circuit has 2 B or "Bearer" channels. These can have the same or different telephone numbers. It is possible to select which of these channels the box will answer.*

Switch on while holding "ANSWER" and "0" = either channel

Switch on while holding "ANSWER" and "1" = B1 only

Switch on while holding "ANSWER" and "2" = B2 only

"POWER" LED lights immediately to confirm set-up operation.

"POWER" LED goes off when "ANSWER" & "n" are released.

"POWER" LED lights and normal operation continues.

## **9) SELECT OUTGOING ISDN B CHANNEL :-**

**Factory Default is any free channel.**

*An ISDN2 circuit has 2 B or "Bearer" channels. These can have the same or different telephone numbers. It is possible to select which of these channels the box will ring.*

Switch on while holding "HOLD TO DIAL" and "0" = any free channel

Switch on while holding "HOLD TO DIAL" and "1" = B1 only

Switch on while holding "HOLD TO DIAL" and "2" = B2 only

"POWER" LED lights immediately to confirm set-up operation.

"POWER" LED goes off when "DIAL" & "n" are released

"POWER" LED lights and normal operation continues.

## **10) STORE FREQUENTLY USED ISDN NUMBERS :-**

**Factory Default setting will not alter any stored numbers.**

*It is possible to permanently store up to 12 frequently used ISDN numbers. Each number may consist of up to 20 digits plus a further 10 digits for sub-addressing. Each of the 12 numbers are represented as one of the 12 keypad numbers 0-9, \* & #.*

Switch on while holding "REDIAL" and "Keypad number" of the store location.

"POWER" LED lights immediately to confirm set-up operation.

Release "REDIAL" and "Keypad number"

Dial number required to be stored.

Turn the box off.

Repeat for other numbers.

### **11) SET SUB-ADDRESS MODE:-**

**Factory Default will not affect the sub-address.**

*It is possible to allocate a sub address to the box. If the network presents a sub address and the box has a sub address set, the box will only ring if these sub addresses match.*

Switch on while holding "ANSWER" and "#"

"POWER" LED lights immediately to confirm set-up operation.

Release "ANSWER" and "#"

Enter sub-address required to be stored.

Turn the box off. (Turning off without entering a sub-address disables sub-address mode).

### **12) SET MSN (MULTIPLE SUBSCRIBER NUMBERING) MODE:-**

**Factory Default will not affect the MSN.**

*It is possible to allocate an MSN number to the box. If the network presents an MSN number and the box has an MSN number set, the box will only ring if these numbers match.*

Switch on while holding "ANSWER" and "\*"

"POWER" LED lights immediately to confirm set-up operation.

Release "ANSWER" and "\*"

Dial number required to be stored. (This must be all digits including the area code).

Turn the box off. (Turning off without entering a number disables MSN mode).

### **13) SET 'ATTENTION' MODE:-**

**Factory Default will not alter this mode.**

*It is possible to sound a 'Beep Beep' noise in the commentators headphones if either the Codec loses lock or if the ISDN line disconnects.*

Switch on while holding "HANG-UP" and "7"

"POWER" LED lights immediately to confirm set-up operation

If the "ISDN LINE" LED is off the Beeps are off.

If the "ISDN LINE" LED is on the Beeps are on.

Press "0" to turn off the Beeps

Press "1" to turn on the Beeps

Turn the box off.

# **HARDWARE CONFIGURATIONS**

## **HEADPHONES**

This equipment is usually supplied with 'split ear' headphone connections. That is cue programme is wired to only the left ear and mixer output is wired only to the right ear. This will produce sensible results with either mono or stereo headphones.

Provision has been made however to mix either or both sources into either or both ears. This is most clearly understood by reference to our drawing number A2-12582. There are 8 possible links that can be made or broken on the PCB GSH84. These links must be made with a soldering iron as follows:-

To access the board remove the 4 screws holding the front panel.  
Open the box. GSH84 is the large PCB attached to the front control panel.  
Study Drawing number A3-12584 which shows the position of the links.  
Bridge the required links with solder.  
Re fit the front panel.

## **HEADSET CONNECTORS**

As standard these units are fitted with Neutric jacks for the headphones. These jacks accept A or B gauge plugs. (The A gauge plugs are captive). Some customers may prefer headsets instead of headphones. Because the panel cut outs are standardized, it is practical to fit Neutric multipin XLRs in place of the headphone jacks.

# MPEG NOTES

If the unit is fitted with our MPEG layer II codec some extra facilities become available.

## MODE OF OPERATION

Our MPEG codec will try to establish lock with the codec at the other end of the ISDN line. It will attempt communication in MPEG at 16, 24, 32 or 48KHz sampling as well as G722. This is achieved by looking at the incoming data and locking onto it. Initially our MPEG codec sends MPEG at 24KHz sampling and so if there is one of our units at both ends of the ISDN line they will settle for this mode.

It is possible to force the codec into any desired mode, but remember that a codec lock will only be achieved if the codec at the other end of the ISDN line is operating in the same mode.

To force the mode you must 'dial' special codes after the line connection has been made. These codes are printed on the rear panel 'CODEC TYPE' label.

AVAILABLE OPTIONS	CODE TO FORCE OPTION			
MODE	G722 = *722	MPEG = *888	AUTO = *000	
SAMPLE FREQU	16KHz = *16	24KHz = *24	32KHz = *32	48KHz = *48
DATA RATE	56KBits/Sec = *56		64KBits/Sec = *64	

After the call is terminated the unit resets itself to the automatic mode.

## AUXILIARY DATA INSTALLATION

If this unit is fitted with an MPEG codec it is possible to fit a 9 pin D socket to the rear panel. The latest version of our GSGC4 and 5 have a hole already punched for this connector, but if you are fitting an MPEG codec to an older GSGC5 and require the auxiliary data facility, it will be necessary to punch a hole or replace the rear panel.

This is a serial port operating at a fixed 9600 baud. It is pin compatible with a PC and provides a data path to another similarly equipped unit at the other end of the ISDN link. The data and audio channels can be used simultaneously and the data has no noticeable effect on the audio quality. This data path only operates if the codec is in the MPEG mode.

ISSUE DATE

1 07/12/99  
 2 28/03/00

GSGC5G  
 ISDN MIXER  
 WITH ADDED  
 EXTERNAL  
 INPUT

DRAWING NUMBER  
**A3-14030**

DRAWN BY

ORIGINALLY DRAWN USING EASYTRAX

# ISDN MIXER GSGC5G

GLENSOUND ELECTRONICS LTD.

SERIAL No.

← BEND

← BEND

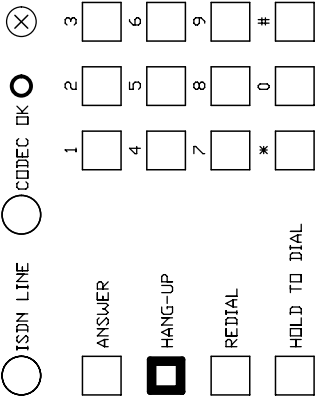

## HOW TO CALL STUDIO

- 1) CONNECT TO ISDN LINE SOCKET
- 2) TURN ON THE BOX WITH SWITCH ON REAR PANEL
- 3) PRESS AND HOLD 'HOLD TO DIAL' BUTTON
- 4) DIAL STUDIO
- 5) RELEASE 'HOLD TO DIAL' BUTTON
- 6) ISDN & CODEC LIGHTS MUST BE ON TO BROADCAST
- 7) PRESS 'HANG-UP' FOR 1 SECOND TO END CALL

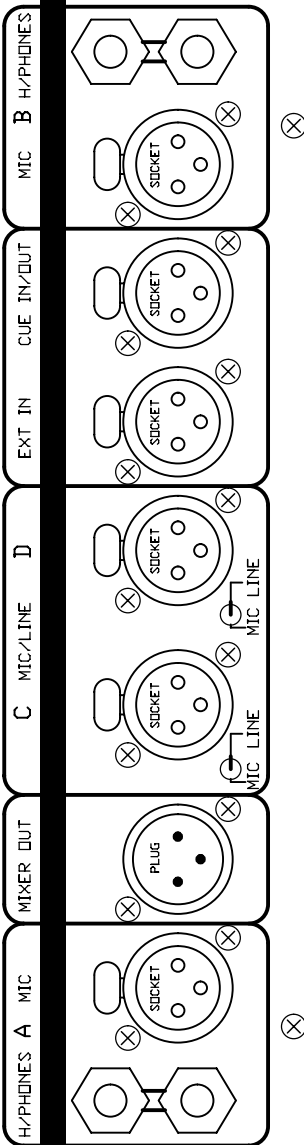
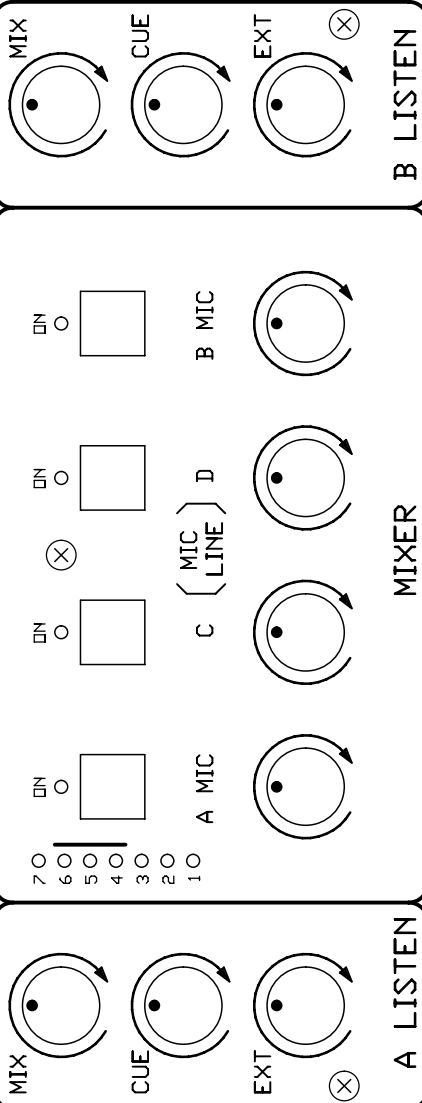

← BEND

← BEND

PCB GSP45

PCB GSK36

DTMF

LED PPM

DIAL

MICRO

PCB GSP46

MIC A

MIC B

MIC C

TAPE C

MIC D

TAPE D

COMPRESSOR

TA

CODEC

ISDN LINE

X21 PORT FOR EXTERNAL TA

MIXER OUT  
CUE IN/OUT  
EXT IN

DC:DC  
4.5V STAB  
EXT DC 6-9V  
3 X D ALKALINE BATTERIES

LOGIC +5V  
AUDIO V+ 0V V-

DTMF DETECTOR

LINK OPTIONS ON PCB

LINK OPTIONS ON PCB

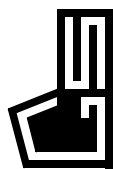

© 2000  
**GLENSOUND**  
ELECTRONICS LTD

BLOCK DIAGRAM OF GSGC5G  
ISDN MIXER

ISSUE	DATE	DRAWING NUMBER
1	28/03/00	A4-14194
2	07/07/00	
ORIGINALLY DRAWN USING EASYTRAX		

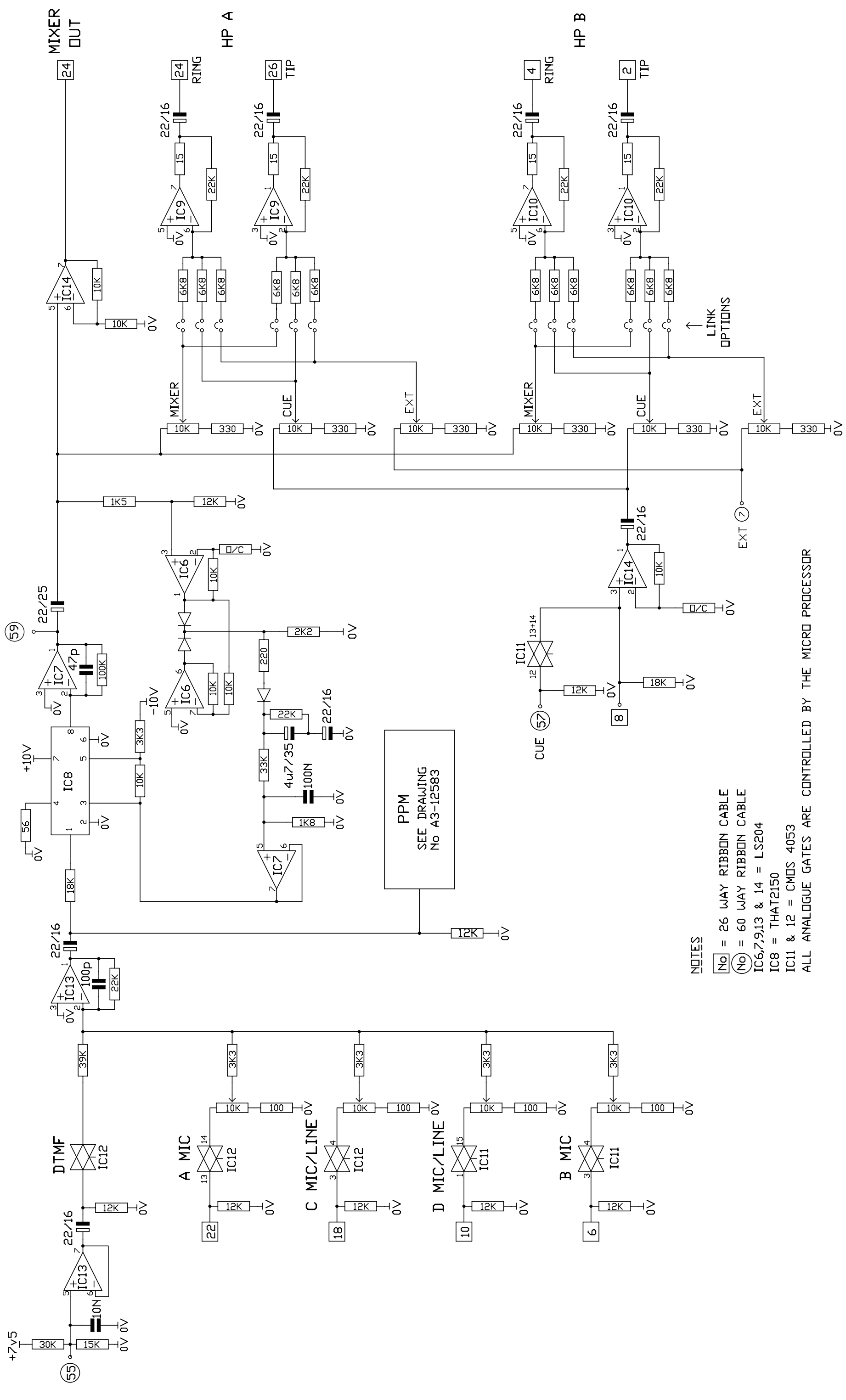

**NOTES**

- (No) = 26 WAY RIBBON CABLE
- (No) = 60 WAY RIBBON CABLE
- IC6,7,9,13 & 14 = LS204
- IC8 = THAT2150
- IC11 & 12 = CMOS 4053
- ALL ANALOGUE GATES ARE CONTROLLED BY THE MICRO PROCESSOR

<p style="text-align: center; margin: 0;"><b>GLEN SOUND</b> ELECTRONICS LTD</p>	<p style="margin: 0;">PART OF GSP45 CIRCUIT DIAGRAM</p>	<p style="margin: 0;">ISSUE 1</p>	<p style="margin: 0;">DATE 20/06/00</p>
<p style="margin: 0;">DRAWING NUMBER <b>A2-14196</b></p>		<p style="margin: 0;">DRAWN BY AMD</p>	
<p style="margin: 0;">DRAWN USING EASYTRAX</p>			

ISSUE	DATE
1	20/06/00
2	31/01/01

GSP46

FRONT PCB FOR

GSGC5G

CIRCUIT DIAGRAM

DRAWING NUMBER

A3-14198

DRAWN BY AMD

DRAWN USING EASYTRAX

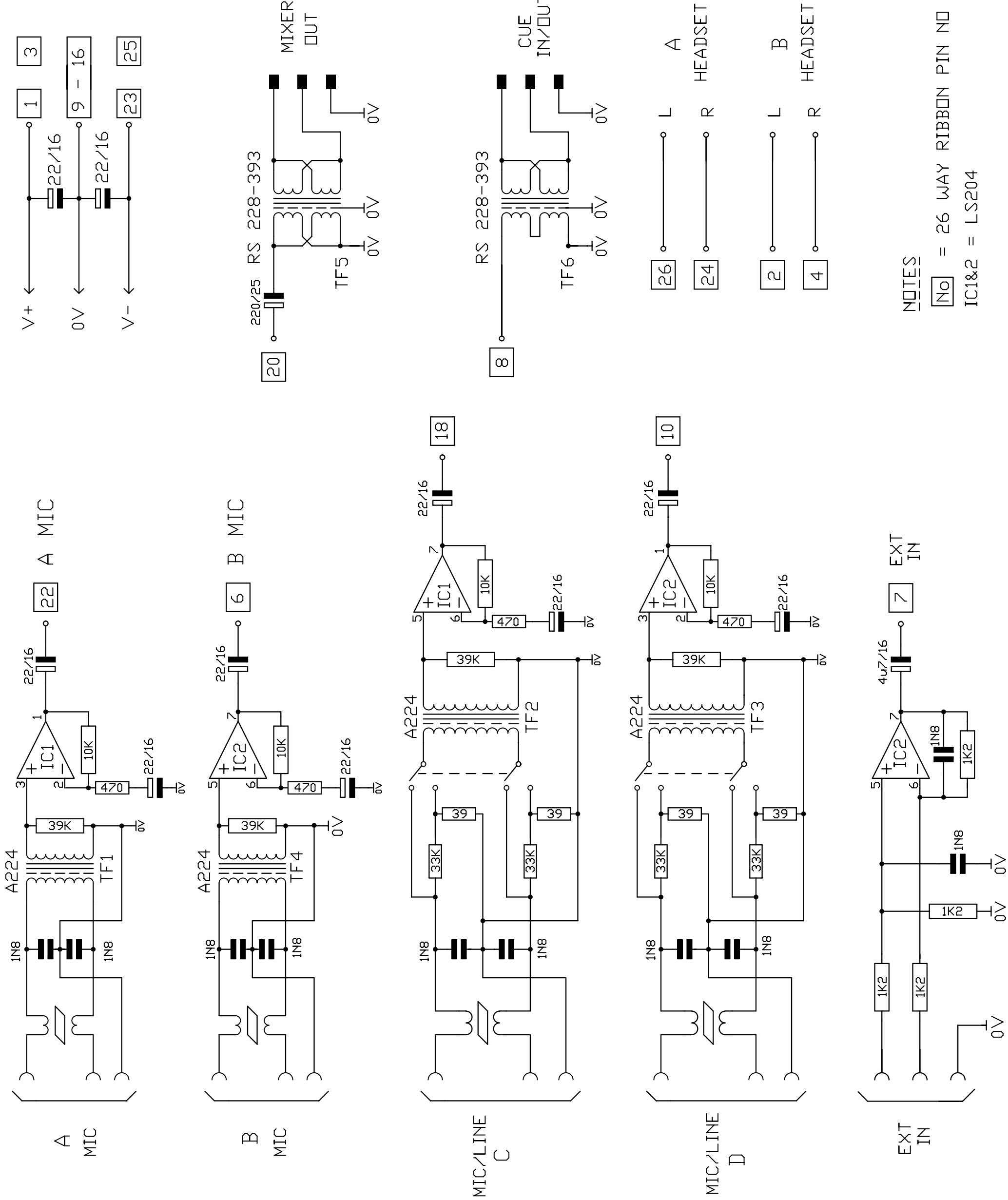

NOTES

[No] = 26 WAY RIBBON PIN NO

IC1&2 = LS204

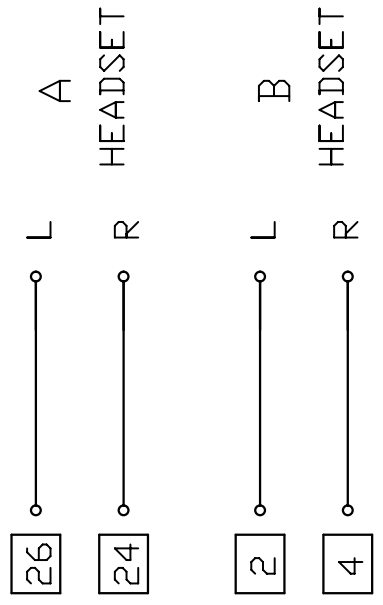



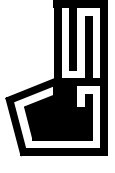

© 2000  
**GLENSOUND**  
 ELECTRONICS LTD

ISSUE	DATE
1	22/06/00

GSP45 TRACKS  
 SHOWING  
 LOCATION OF  
 SOLDER BRIDGES  
 TO CO-FIGURE  
 HEADPHONES

DRAWING NUMBER	A3-14199
DRAWN BY	
ORIGINALLY DRAWN USING AUTOTRAX	

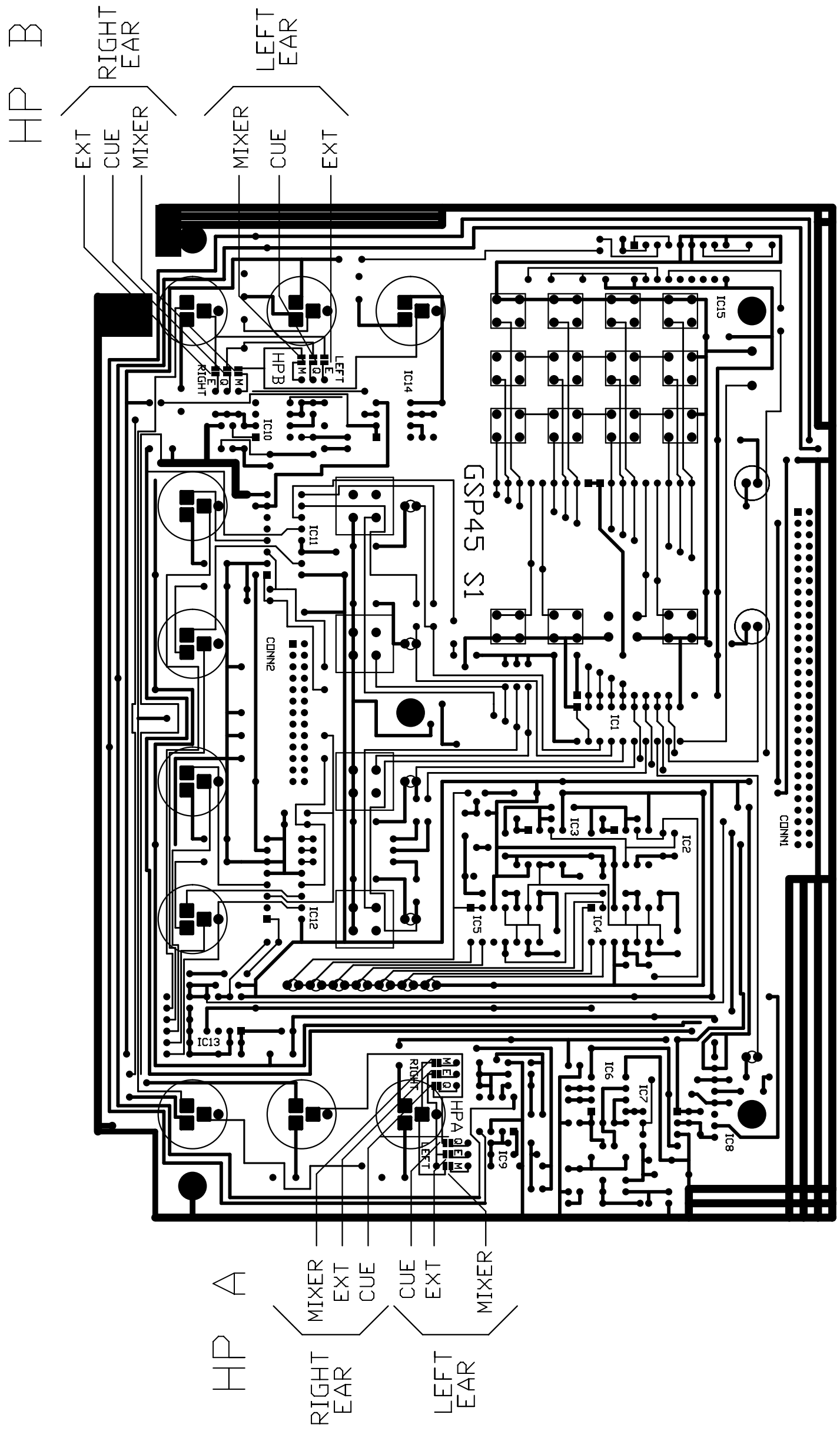

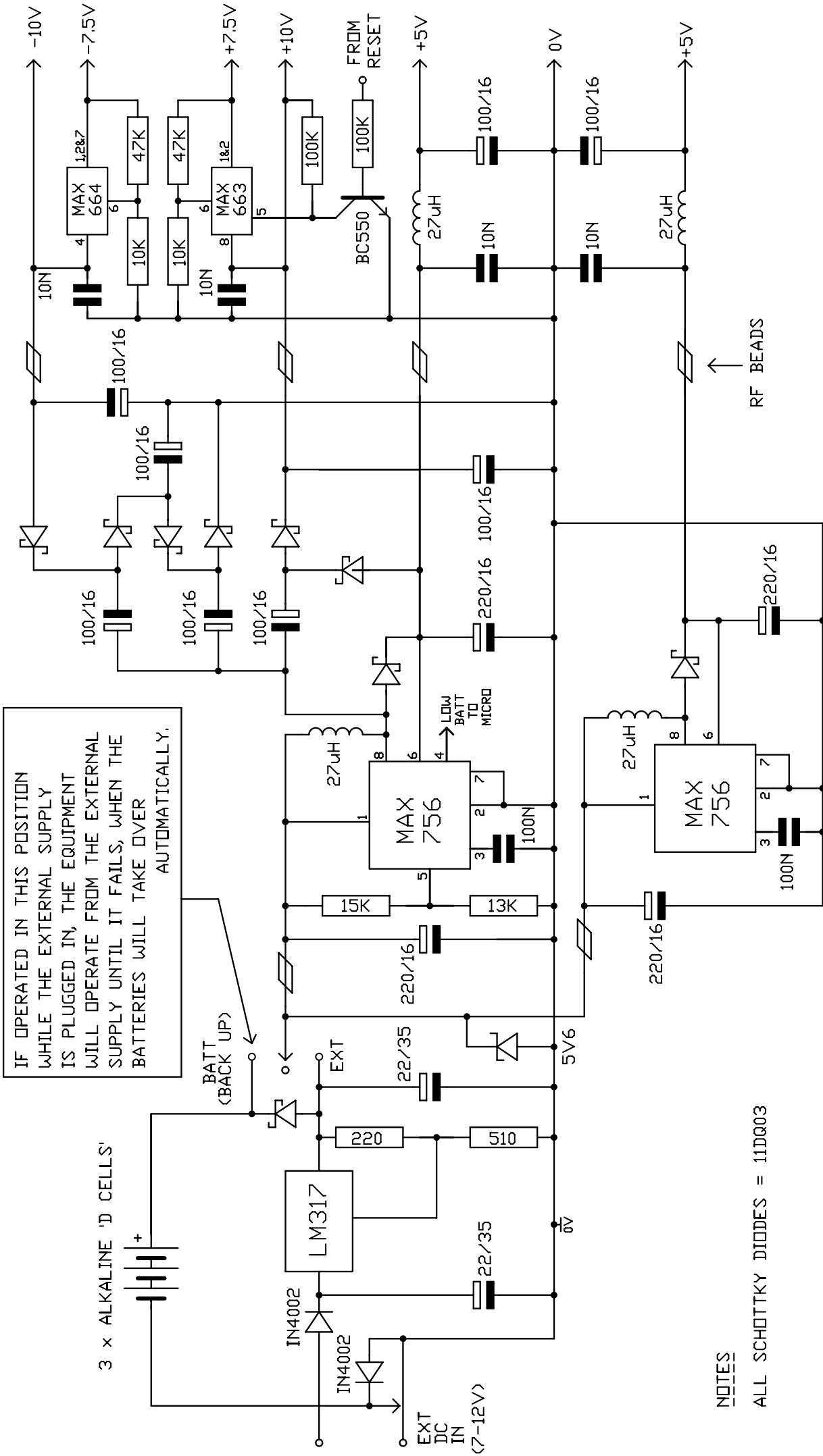

IF OPERATED IN THIS POSITION WHILE THE EXTERNAL SUPPLY IS PLUGGED IN, THE EQUIPMENT WILL OPERATE FROM THE EXTERNAL SUPPLY UNTIL IT FAILS, WHEN THE BATTERIES WILL TAKE OVER AUTOMATICALLY.

NOTES  
ALL SCHOTTKY DIODES = 11DQ03

ISSUE	DATE	DRAWING NUMBER
2	08/04/94	A4-12580
3	21/04/94	
4	12/04/95	
5	05/06/00	

PART OF GSH83  
POWER SUPPLY DIAGRAM

© 1994  
  
**GLENSOUND**  
 ELECTRONICS LTD

# GLENSOUND ELECTRONICS LTD

---

## SPECIFICATION for GSGC4/5 ISDN MIXER

---

### MIC INPUTS MEASURED AT MIXER OUTPUT

Input Impedance	1k-1k5 ohms transformer balanced
Frequ. Response	40Hz-10kHz +/- 0.5dB
Gain Range	-30dBu to -70dBu for PPM4 Line Up
THD with -3dBu out	<0.2% (Frequ= 40Hz-7kHz)
Noise at max gain	< -50dBu RMS (20Hz-20kHz) (i/p = 300 ohms)

### TAPE INPUT MEASURED AT MIXER OUTPUT

Input Impedance	> 15k ohms electronically balanced
Frequ. Response	40Hz-10kHz +/- 0.5dB
Max Gain	10dB
THD with -3dBu out	<0.2% (Frequ= 40Hz-10kHz)
Noise at max gain	better than -63dBu CCIR Quasi Pk Unweighted

### MIXER OUTPUT

Output Impedance	< 40 ohms transformer balanced
Level	0dBu at line up +8dBu max (Limited)
Limiter Threshold	0dBu
Compression Ratio	Starts gently and increases to 5:1 max

### CUE INPUT

Input Impedance	> 15k ohms transformer balanced
Frequ Response	40Hz-10kHz +/- 0.5dB
Gain	10dB to HP with HP vol at max

### CUE OUTPUT

Output Impedance	100 ohms approx. transformer balanced
Level	+14dBu With Max digital code from ISDN Line

### HEADPHONE OUTPUTS

This equipment is designed to be used with medium to high impedance headphones in the range of 300 ohms to 2K ohms

Output Impedance	<50 ohms
Max Output	+15dBu into 2kohms. +12dBu into 300 ohms

## POWER

These units are normally battery operated :-

Internal Batt Type	3 off D size Alkaline Cells
Batt Life	The battery life is codec dependent. Approximate figures are :- G722 Codec More than 10 Hours APTX Codec 10 Hours Dual Codec 8 Hours MPEG Codec 6 Hours

Provision is also made for an external DC supply :-

Ext. DC Connector	2.5mm Mates with RS 486-634
Ext. DC Volts	6 to 9 volts DC (Sleeve is -ve)

## ISDN CIRCUIT

Line	Uses 1 off ISDN2 B Channel at 64kbit/s
Connector	RJ45
Standards	This equipment operates correctly with ISDN2 circuits which meet any one of the following specs:- ETSI Euro ISDN (Net 3) BTNR 191 I 420

## CODECS

Option 1	G722 Locking by Statistical Analyses
Option 2	APTX100
Option 3	Dual Codec (APTX & G722) This codec automatically detects the system in use at the other end of the ISDN link and sets itself to agree. No operator action is required.
Option 4	ISO/MPEG Layer 2 This codec first sends MPEG code at a 24KHz sample rate. After approximately 2 secs it sends G722 code instead. If, at any time, it receives G722 code or MPEG code at 48, 32, 24 or 16 KHz sample rate it will automatically start sending the same code at the same sample rate. It is possible to force this codec to operate in any particular mode by dialing special codes.
Line Up	Max digital code = +14dBu

## SW56 OPERATION

This X version of the GSGC4 or 5 will operate as the ISDN end of a circuit whose other end is operating on a switched 56 service. This unit will not operate if connected directly to a switched 56 exchange.